

If you need further information  
or assistance, please contact your  
Genuine Stromberg dealer,

or email us direct at  
**tech@stromberg-97.com**

or log on to our Tech Center at  
**www.stromberg-97.com**

© Stromberg Carburetor

**GENUINE  
STROMBERG**



# INSTALLATION GUIDE

**Your guide  
to Stromberg 97  
carburetor  
installation and  
adjustment**

This Guide will help make the installation and adjustment of your new Genuine Stromberg carburetor as safe, satisfying and trouble-free as possible. It contains several warnings, cautions, notes and illustrations, some of which may seem obvious to you. Please read them anyway.

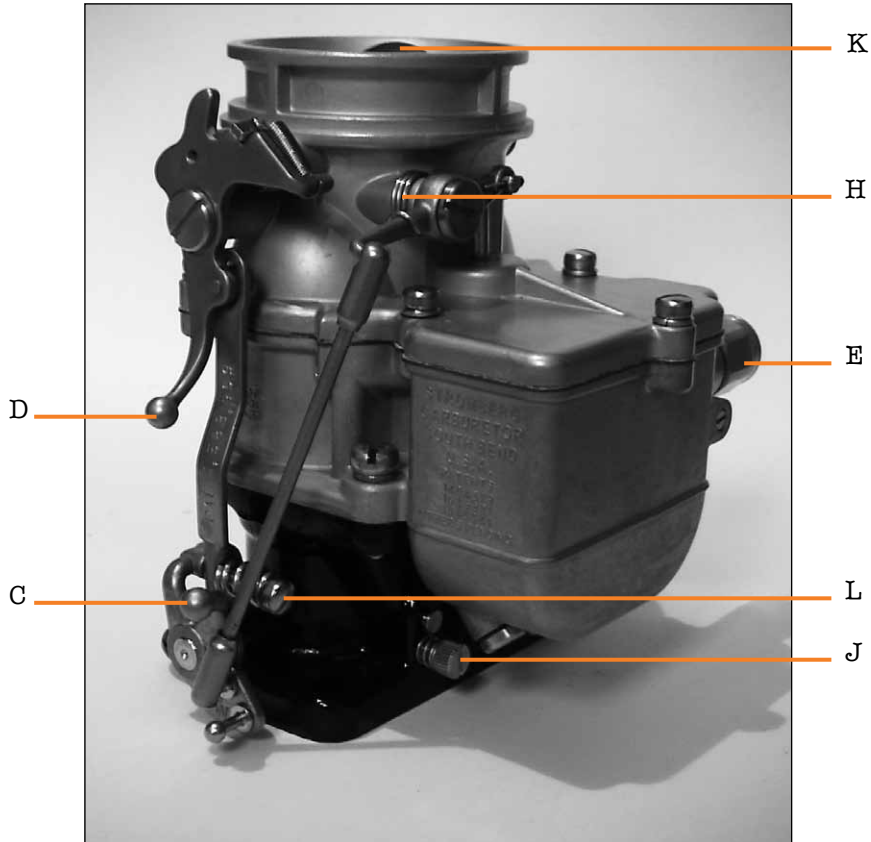

**Work Safe!**

If you have any questions or are unclear about the installation, the carburetor, or any part of this Installation Guide, please call your dealer or contact us at [tech@stromberg-97.com](mailto:tech@stromberg-97.com)

Every new Genuine Stromberg 97 is individually numbered. You can register your new Stromberg 97 by completing and mailing the card enclosed with these instructions, or online at [www.stromberg-97.com](http://www.stromberg-97.com)

Pre-installation Checklist	05
Remove Existing Carburetor	06
Install New Stromberg Carburetor	07
Attach the Linkage	08
Connect the Fuel Line	08
Install the Air Cleaner	10
Start the Engine	10
Tuning	12
Troubleshooting	13
Maintenance	13

### Warnings! and Notes

These instructions must be read and fully understood before beginning installation. If these instructions are not fully understood, installation should not be attempted. Failure to follow these instructions, including illustrations, may result in poor performance, vehicle damage, property damage, severe personal injury or death, and may void your warranty. If you need information or assistance, please contact your Genuine Stromberg dealer or email us direct at [tech@stromberg-97.com](mailto:tech@stromberg-97.com)

### WARNING!

Gasoline and gasoline vapors are very flammable. Therefore, make sure that the engine is cool before beginning the installation of this carburetor. Never smoke, use an open flame, or produce any sparks in an area where gasoline or gasoline vapors could be present. Doing so may cause a fire or explosion, resulting in property damage, serious personal injury, or even death.

### WARNING!

Always perform any work on the fuel system in a well ventilated area. Failure to do so may result in the build up of dangerous gasoline vapors, causing severe respiratory injury or death, causing a fire or explosion, resulting in property damage, serious personal injury, or death.

### WARNING!

A thorough knowledge of the vehicle's mechanical and electrical systems is required. Therefore, Stromberg recommends installation by a professional mechanic only.

An improperly installed carburetor may cause poor performance or lead to property damage, personal injury, or death, and may void your warranty.

### WARNING!

This carburetor is not to be used in MARINE or AIRCRAFT applications.

**NOTE:** This carburetor is not designed to pass any emissions laws. It is to be used only for competition/off-road vehicles or vehicles not required to comply with any exhaust emissions standards.

This Genuine Stromberg 97 carburetor has been built and calibrated to original factory specification. It is supplied as standard with 0.045" main jets, a No. 65 power valve and factory float level setting. However, different settings may be required for altitude, other and non-standard engines; multiple carburetion; forced induction or special fuels; and local and seasonal differences in fuel formulations.

In some areas, fuels can contain comparatively large percentages of ethanol. While your Stromberg 97 carburetor will operate on this fuel, its performance may be impaired if it is not retuned.

**CAUTION:** Carburetor retuning should always be carried out by a specialist since improper tuning could invalidate your warranty.

## 1. Pre-installation Checklist

a) Inspect carburetor for possible shipping damage. Verify that all linkages operate freely by manually opening the throttle butterflies (throttle plates) to Wide Open Throttle (See A) and back closed without any binding.

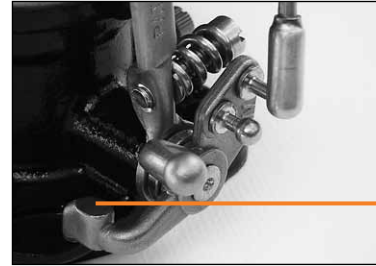

b) Do you have the correct throttle and choke linkage and fuel supply for your particular application? Use only parts sold specifically for use with Stromberg 97 carburetors on your engine/vehicle.

c) Hand throttle linkage parts (See B) are not supplied. If required, please install the parts from your old Stromberg carburetor. Please inspect any parts from your old carburetor for wear or damage prior to installation.



### WARNING!

Do not use the carburetor if the linkage binds in any way. Failure to do so may result in improper functioning of the throttle and uncontrolled speed which can cause property damage, serious personal injury, or death.

◀ Open out flap and use diagram together with installation instructions

## 2. Remove Existing Carburetor

The initial step in the installation of your new Genuine Stromberg carburetor is to remove any existing carburetor following the procedure outlined below.

### WARNING!

Never smoke, use an open flame or produce any sparks in an area where gasoline or gasoline vapors are present. Doing so may cause a fire or explosion, resulting in property damage, serious personal injury, or death.

### WARNING!

Always perform any work on the fuel system in a well ventilated area. Failure to do so may result in the build up of dangerous gasoline vapors, causing severe respiratory injury or death. It can also cause a fire or explosion, resulting in property damage, serious personal injury, or death.

### WARNING!

Always disconnect your vehicle's battery before performing any work on the vehicle's fuel system. Failure to do so may produce sparks, causing a fire or explosion, resulting in property damage, serious personal injury, or death.

### WARNING!

Make sure that the engine is cool before beginning the installation of this carburetor. Failure to do so may cause a fire or explosion, resulting in property damage, serious personal injury, or death.

### WARNING!

Insure that your vehicle's ignition switch is off.

- a) Disconnect the vehicle's battery and carefully remove the air cleaner.
- b) Disconnect all linkages (i.e. throttle and choke - at C & D).
- c) Carefully disconnect the fuel line from the existing carburetor (at E).

**NOTE:** Disconnecting fuel lines will usually result in some gasoline being spilled. Use a catch bottle to collect excess fuel. Clean up any spilled gasoline before continuing.

- d) Unbolt and remove the carburetor from the intake manifold.
- e) Remove all traces of the old gasket from the manifold mounting flange and clean manifold face.

**NOTE:** Do not allow gasket or other materials to fall into the manifold.

## 3. Install New Stromberg Carburetor

- a) Verify that the mounting surface of the intake manifold (and any spacers or adapters) is completely flat.

### WARNING!

Before beginning installation of the carburetor, verify that all mechanical and electrical systems are in good working order. These include engine components like intake manifold and gaskets, electrical components including but not limited to distributor, spark plug wires, battery, battery cables, starter, and starter solenoid, and fuel system including fuel tank and fuel lines. Any damaged or improperly operating components must be replaced prior to installing the carburetor. Failure to do so may result in property damage, serious personal injury, or death.

### WARNING!

Any damaged, warped, or heat-checked intake components must be replaced prior to installing the carburetor. In addition to poor performance, failure to do so may result in an improperly functioning throttle and uncontrolled speed, or component failure or gas vapor that may ignite - any of which may cause property damage, serious personal injury, or death.

### WARNING!

This carburetor is not designed for use with engines or transmissions requiring carburetor vacuum lines, or any computer-controlled applications. Use with these applications may cause damage.

- b) Inspect carburetor mounting studs (see F) or bolts to insure that they are straight. New studs, spring washers and nuts are available from your Genuine Stromberg dealer (kit 89067k-3).
- c) Place the new carburetor manifold gasket - supplied (see G) - in the correct position on the intake manifold studs.

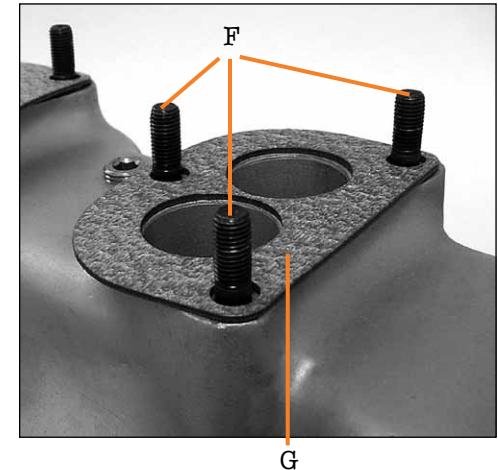

**NOTE:** Use the gasket dry. Do not use any cement, glue or RTV sealant.

- d) Place carburetor on top of the manifold gasket on the studs. Install washers, then nuts. Tighten nuts in a progressive manner to a recommended 15 ft./lbs. of torque.

**CAUTION:** Do not overtighten the mounting nuts or bolts. Overtightening can result in damage to the manifold, manifold studs, or carburetor base, that is not covered under warranty.

#### **4. Attach the Linkage**

- a) Attach the throttle linkage to the carburetor (see C). Have a second person operate the throttle linkage from inside the vehicle - opening to Wide Open Throttle and back to idle while you inspect throttle operation on the carburetor.

#### **WARNING!**

Check and correct assembled linkage for interference, sticking or binding action. Any sticking, binding, or 'over-center' movement could result in uncontrolled engine speed, property damage, serious personal injury, or death.

- b) Attach choke linkage (at D), insuring no interference, binding, or sticking when operated from inside the vehicle. Insure that choke plate is vertical (see K above) when choke control is in the 'off' position.

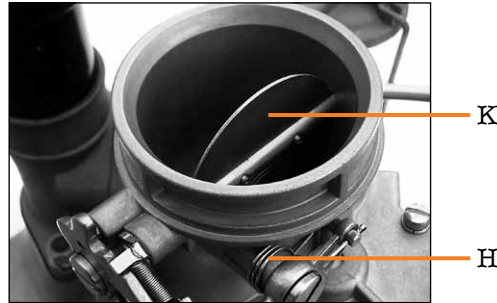

#### **WARNING!**

Always use a throttle return spring that has sufficient tension to return the carburetor to idle when the throttle is not depressed. Failure to use an effective throttle return spring may result in uncontrolled engine speed, property damage, serious personal injury, or death. Do NOT rely on the carburetor accelerator pump lever return spring (see H) to act as your throttle return spring.

#### **5. Connect the Fuel Line**

- a) Install the correct fuel line to the S-jet inlet fitting (at E). Do not fully tighten the fitting at this time.

#### **WARNING!**

Use only rubber and steel fuel lines approved for automotive fuel applications. Failure to do so may cause fuel leaks which may cause a fire resulting in property damage, serious personal injury, or death.

#### **WARNING!**

Never use teflon tape or thread sealant on the fuel inlet fittings or rubber hose. Teflon tape and other sealants are not to be used on taper seat fittings and may cause fuel leaks which may cause a fire resulting in property damage, serious personal injury, or death.

**CAUTION:** Before proceeding, make sure the fuel line does not touch the intake manifold or any other engine parts.

**CAUTION:** Thoroughly flush the fuel lines before connecting to the carburetor. Do not allow any dirt or other particles to enter the carburetor fuel system as it could cause damage to the S-jet fuel inlet valve.

- b) If you are using the original type metallic fuel line, loosen (about a turn), but do not remove, the fuel line fitting at the fuel pump outlet.



#### **WARNING!**

If you are using rubber fuel hose, insure that the hose clamps are secure and check the condition of the hose. If there are any signs of cracking or fatigue in the hose, replace it immediately. Failure to do so may result in fuel leaks which may cause a fire or explosion resulting in property damage, serious personal injury, or death.



**CAUTION:** When connecting the fuel line, hold the S-jet inlet fitting (see above) with an 11/16-inch open-end wrench. This fitting must not be allowed to turn in the carburetor. If the fitting is allowed to turn, it could upset the pre-set float level adjustment, which can cause carburetor malfunction and flooding.

**CAUTION:** Running without a fuel filter voids the carburetor warranty. It is essential that a quality inline fuel filter is installed between the fuel tank and carburetor. This is mandatory as a safeguard against possible flooding which could result from unfiltered foreign particles becoming lodged inside the fuel inlet valve. Filter elements should be cleaned or replaced regularly to assure maximum protection. Always use new, clean fuel.

- c) Go back and tighten ALL the fuel line fittings on the carburetor, fuel pump and any fuel distribution block. Be sure not to over-tighten the fittings.

## 6. Install the Air Cleaner

- a) Check for adequate clearance between air cleaner and carburetor linkages and fuel lines.
- b) Check for adequate clearance between air cleaner and hood before closing hood completely.

### WARNING!

Check and correct for air cleaner-to-carburetor as well as air cleaner-to-hood interference that may cause the linkage to stick or bind. Any sticking, binding, or 'over-center' movement could result in uncontrolled engine speed, property damage, serious personal injury, or death.

**CAUTION:** Running without an air cleaner is strongly discouraged. Dirt and varnish will accumulate and upset the carburetor air/fuel metering balance. Dirt and debris can also enter the fuel bowl causing further problems.

**NOTE:** Any air filter element must be clean and of sufficient capacity to pass 250 cfm of air per carburetor. Check with your air cleaner supplier as lower capacities can cause rich running conditions.

## 7. Start the Engine

- a) Prime the carburetor: Crank the engine over to fill the carburetor. If the vehicle is equipped with an electric fuel pump, you will need to reconnect the battery. After reconnecting the battery, pulse the fuel pump on and off to fill the carburetor.

### WARNING!

Protective eyewear must be worn before the fuel pump is first turned on. Failure to do so may result in injury to the eyes or blindness.

### WARNING!

If you crank the engine over, make sure the ignition is disabled by removing the coil wire from the distributor. Failure to do so may cause a fire or explosion resulting in property damage, serious personal injury, or death.

### WARNING!

Because of the inherent danger of gasoline and gasoline vapors, you should have a helper ready with a fire extinguisher before removal and installation of any carburetor.

### WARNING!

Watch closely for signs of fuel flooding when the fuel pump is first turned on or when the engine is first started. If flooding is apparent, stop the engine immediately. Disconnect the fuel line, remove the fuel inlet fitting (see E) and check for blockage or dirt. Clean as required, reinstall fitting and reconnect fuel system. Clean up any raw fuel. Flooding does not necessarily indicate a faulty carburetor.

### WARNING!

The Stromberg 97 carburetor is designed for fuel pressure between 2.5 psi and 3.0 psi **MAXIMUM** measured at the carburetor. Excess pressure can cause flooding which may cause a fire or explosion resulting in property damage, serious personal injury, or death. Many modern electric fuel pumps are designed to provide higher pressures and are not suitable for Stromberg carburetor applications without a fuel regulator of the correct range. Always check the manufacturer's specification.

### WARNING!

If your vehicle is equipped with an automatic transmission, confirm that the transmission is in park before starting. If your vehicle is equipped with a manual transmission, verify that the vehicle is in neutral with the parking

brake activated before starting. Failure to do so may result in unintended vehicle movement resulting in property damage, serious personal injury, or death.

**NOTE:** If the fuel inlet fitting is removed for any reason, the float level must be rechecked and possibly readjusted. (Instructions can be found on the Stromberg website at [www.stromberg-97.com](http://www.stromberg-97.com)).

- b) Check for leaks at fuel line and inlet fittings.
- c) Start engine and recheck for leaks at fuel line and inlet fittings.



## 8. Tuning

a) Set the idle:

- 1) Set idle using the idle needle valves (screws) (see J) with the engine at normal operating temperature, the air cleaner in place, the throttle fully closed, and the choke fully open (see K). Turn the idle screws IN (clockwise) to provide a leaner mixture and OUT (counter-clockwise) to provide a richer mixture.
- 2) First, screw both screws in (clockwise) until they just touch their seats. Then back them out two turns each. Adjust the idle mixture screws one at a time. Turn the first idle screw in slowly (1/4 turn at a time) until the engine begins to lag or run irregularly. Then turn the same screw out slowly until the engine begins to roll or gallop, then back in slightly to provide the smoothest idle. Repeat this same procedure to adjust the other screw. Re-adjust the first screw if required.

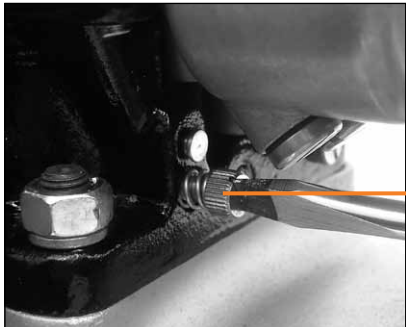

**NOTE:** The use of an engine vacuum gauge to adjust the idle is advisable. If used, set the screws to provide the highest and most steady manifold vacuum reading at idle.

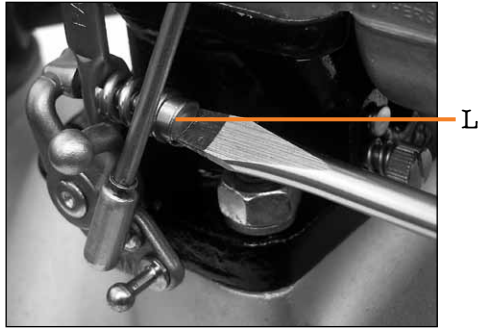

- 3) With the engine at operating temperature and the choke plate fully open, set the idle speed (rpm) to the manufacturer's recommended setting using the throttle stop screw (see L). Turn the screw clockwise for faster idle speed - counter-clockwise for slower idle speed.

**NOTE:** In some areas, 'winter' fuel blends are used to assist in cold-engine starting and drivability. Since these fuels can result in excessive fuel vaporization if the engine is operated in a heated area such as a garage, setting the idle can be more difficult because excess vapor is drawn into the throat and enriches the mixture. The idle will be erratic and may seem unable to hold a set. It is advisable, therefore, to perform the final settings outdoors after the engine has been brought to operating temperature.

- b) Winter and Summer Settings: Your new Stromberg 97 carburetor is supplied with the accelerator pump rod in the W (Winter) position on the throttle linkage. The S (Summer) and W settings partially determine the volume of enrichment fuel discharged into the venturi when the accelerator pump is rapidly depressed. The linkage will discharge greater enrichment in the W position. The correct setting should be determined by the driver to suit local operating conditions. If the vehicle tends to stumble on acceleration, try changing the rod to the other position, then try the acceleration test again.

**NOTE:** Since available fuel formulations vary with the seasons, tuning settings may require readjustment throughout the year.

## 9. Troubleshooting

- a) Carburetors can be frustratingly difficult to troubleshoot and are often blamed for every possible engine-related difficulty. Please check and verify the condition of the complete engine system before proceeding with any carburetor work.

**NOTE:** Proper engine compression, timing, spark plug gap and heat range, distributor point condition and wiring, valve lash and other factors are very important to optimum engine efficiency and performance. There should be no vacuum leaks. The carburetor float and the ignition timing should be properly set. Tuning the carburetor will not cure bad valves, incorrect timing, or poor compression.

## 10. Maintenance

- a) After an initial running period, check and retighten all nuts and screws as required. The presence of liquid fuel demands further checks.

### **WARNING!**

Fuel system components operating under severe conditions, such as high under-hood temperatures, should be periodically inspected to insure no fuel leakage, the fasteners are tight, and the hoses are sound. High temperatures promote faster ageing of non-metallic materials. Metallic materials can age with engine vibration and may warp or fatigue if not properly assembled and maintained.